

Constant temperature controller

ACD20

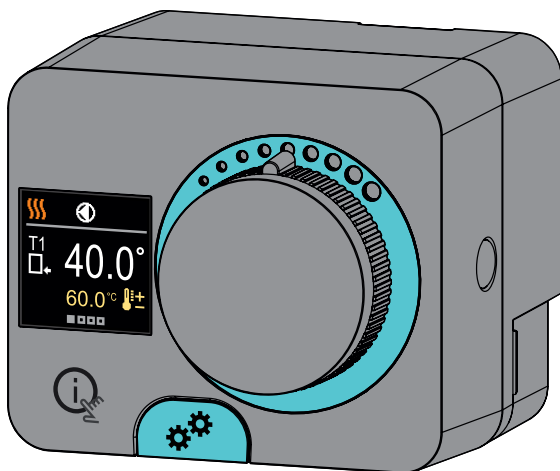

Instructions for versions and up:
SW v2.1r0 - HW 1.0.0,
SW v3.1r0 - HW 2.0.0,
SW v3.3r0 - HW 2.1.0.

CONSTANT TEMPERATURE CONTROLLER ACD20

EN

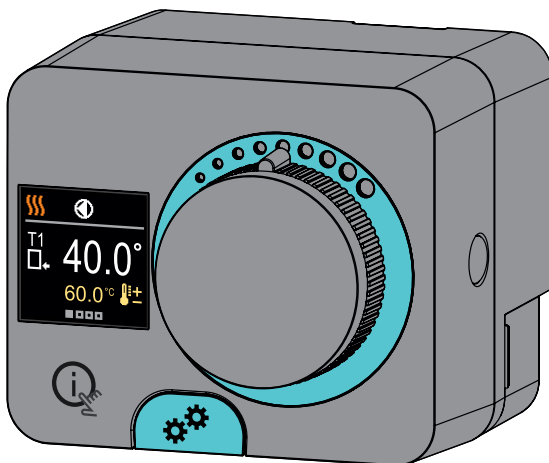

INTRODUCTION

ACD20 controllers are modern microprocessor-controlled devices with an integrated actuator for the mixing valve and circulation pump control. They are produced in digital and SMT technology. They are designed to control constant temperature in various heating and cooling applications. They are most commonly used for the control of the return temperature to the boiler or the supply temperature to the system.

Introduction3

INSTALLATION FOR USE





Appearance of the controller.....6
Initial controller setup7
Basic screens 11
Help 14
Entering and navigating through the menu 14
Menu structure and description..... 15
Requested temperatures 16
Operation mode 18
Information.....20
Display.....23
Statistics 26
User P parameters 28
Service S parameters 31

INSTALLATION INSTRUCTIONS

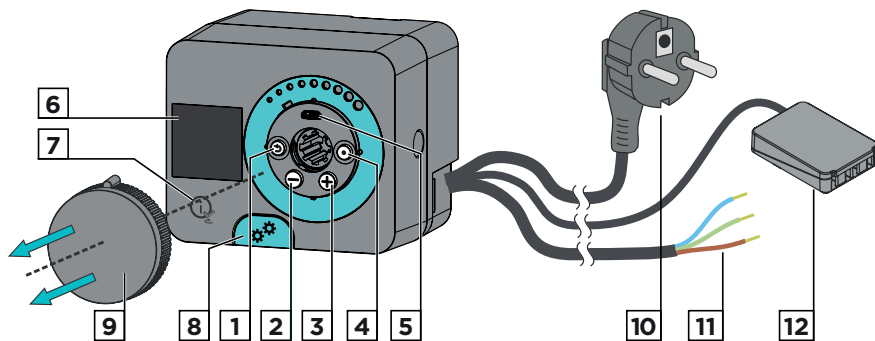
Factory settings41
Clutch and manual valve displacement42
Controller installation.....43
Controller power connection.....45
Operation modes with sensor failure.....46
AUX function at COM input.....47
Technical data.....48
Hydraulic schemes49



APPEARANCE OF THE CONTROLLER



1. Button . Return back.
2. Button . Move to the left, decreasing.
3. Button . Move to the right, increasing.
4. Button . Menu entry, confirmation of selection.
5. USB port for software updates and connection to a personal computer.
6. Graphic display.
7. Button . Help.
8. Manual operation clutch.
9. Manual movement button.
10. Pre-wired power cord with plug.
11. Pre-wired cable for circulation pump.
12. Pre-wired connection box for sensors and communication.

The controller is equipped with an innovative "Easy start" function, which allows the initial setting of the controller in just a few steps.

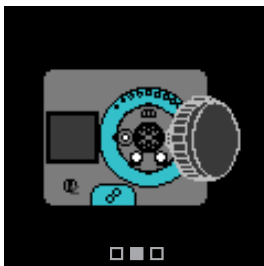

Upon the first connection of the controller to the power supply network, the first step of the controller setup is displayed after the program version and the logo.

The manual movement button must be removed for the setup. The Easy start function is activated by pressing the buttons  and  and holding them both down together for 5 seconds.

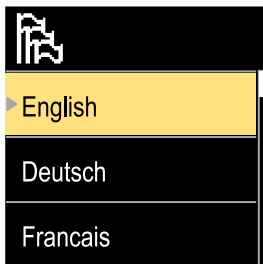

STEP 1 - LANGUAGE SELECTION



Use the buttons  and  to select the requested language. Confirm the selected language by pressing .

If you've mistakenly selected the wrong language, you can return to the language selection with the  button.

i *Later, you can change the language in the "Display" menu.*

STEP 2 - SELECTING HEATING OR COOLING OPERATION

Use the buttons \ominus and \oplus to select the requested operating mode - heating or cooling.
Confirm the selected operating mode by pressing \odot .

If you've mistakenly selected the wrong operating mode, you can return to the operating selection with the button \odot .

i Later, you can change the operating mode in the "Operating mode" menu.

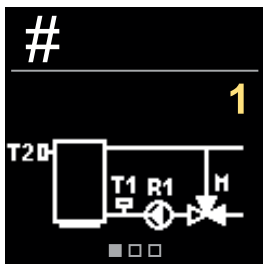
STEP 3: HYDRAULIC SCHEME SETUP.

You can select the hydraulic scheme for the controller operation. Use the buttons \ominus and \oplus to navigate between schemes.
Confirm the selected scheme with the \odot button.

If you have mistakenly selected the wrong scheme, you can return to the diagram selection with the button \odot .

i Later, you can change the hydraulic scheme with the S1.1 service parameter.

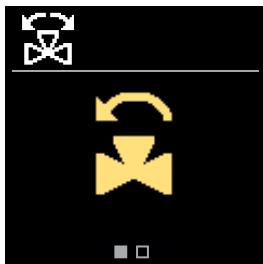
STEP 4: SELECTING THE OPENING DIRECTION OF THE MIXING VALVE.

You can select the opening direction of the mixing valve. Use the buttons \ominus and \oplus to navigate between directions. Confirm the selected direction with the \odot button.

If you have mistakenly selected the wrong direction, you can return to the direction selection with the \odot button.

i Later, you can change the opening direction of the mixing valve with the service parameter S1.3.

STEP 5: SETTING THE LOWER LIMIT FOR THE REQUESTED HEATING TEMPERATURE

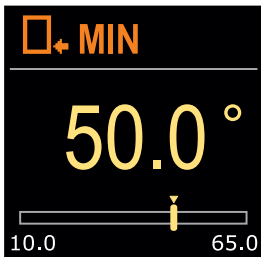

With the buttons \ominus and \oplus you can set up the lower limit of the requested temperature in heating mode. Confirm the setup by pressing \odot .

If you have accidentally set the wrong lower limit, you can return to the lower limit setting by pressing \odot .

i Later, you can change the lower limit setting of the requested heating temperature with the service parameter S2.1.

STEP 6: SETTING THE UPPER LIMIT FOR THE REQUESTED HEATING TEMPERATURE

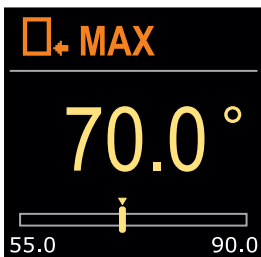

With the buttons \ominus and \oplus you can set up the upper limit of the requested temperature in heating mode. Confirm the setup by pressing \odot .

If you have accidentally set the wrong upper limit, you can return to the upper limit setting by pressing \odot .

i Later, you can change the upper limit setting of the requested heating temperature with the service parameter S2.2.

STEP 7: SETTING THE REQUESTED HEATING TEMPERATURE

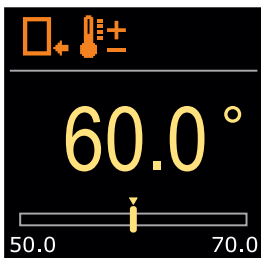

With the buttons \ominus and \oplus you can set up the requested temp. in heating mode. Confirm the setup by pressing \odot .

If you have accidentally set the wrong requested temperature, you can return to the requested temperature setting by pressing \odot .

i Later, you can change the requested heating temperature in the "Requested temperatures" menu.

i  For schemes with stand-pipe control, the supply temperature symbol is displayed.

STEP 8: SETTING THE LOWER LIMIT FOR THE REQUESTED COOLING TEMPERATURE

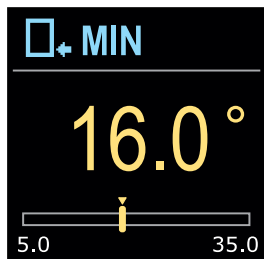

With the buttons \ominus and \oplus you can set up the lower limit of the requested temperature in cooling mode. Confirm the setup by pressing \odot .

If you have accidentally set the wrong lower limit, you can return to the lower limit setting by pressing \odot .

i Later, you can change the lower limit setting of the requested cooling temperature with the service parameter S2.3.

STEP 9: SETTING THE UPPER LIMIT FOR THE REQUESTED COOLING TEMPERATURE

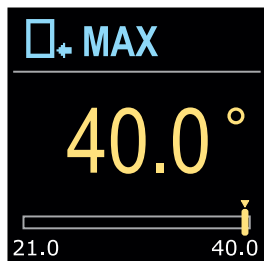

With the buttons \ominus and \oplus you can set up the upper limit of the requested temperature in cooling mode. Confirm the setup by pressing \odot .

If you have accidentally set the wrong upper limit, you can return to the upper limit setting by pressing \odot .

i Later, you can change the upper limit setting of the requested cooling temperature with the service parameter S2.4.

STEP 10: SETTING THE REQUESTED COOLING TEMPERATURE

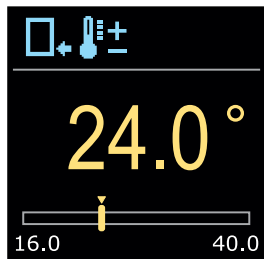

With the buttons \ominus and \oplus you can set up the requested temperature in heating mode. Confirm the setup by pressing \odot .

If you have accidentally set the wrong requested temperature, you can return to the requested temperature setting by pressing \odot .

i Later, you can change the requested cooling temperature can be later changed in the "Requested temperatures" menu.



For schemes with stand-pipe control, the supply temperature symbol is displayed.



All important data on the operation of the controller can be seen in the eight basic screens. Use the buttons ⊖ and ⊕ to navigate between the basic screens.

STATUS BAR

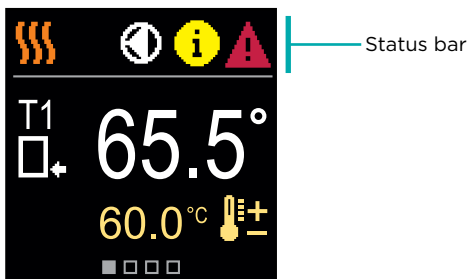
Operating mode, notifications and alerts appear in the top third of the screen.



Symbol	Description
	Room heating.
	Room cooling.
	Manual operation mode.
	Switch off.
	Circulation pump is working.
	Turn the valve to the left.
	Turn the valve to the right.
	Manual intervention - the clutch is activated.
AUX	AUX function at COM input



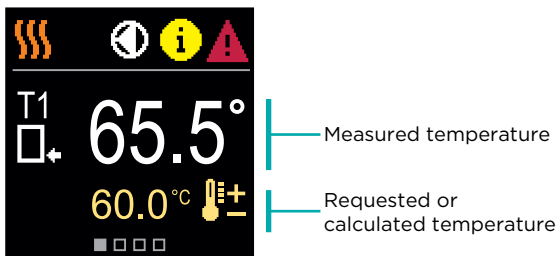

Symbol	Description
	<p>Message</p> <p>In the event that the maximum temperature is exceeded or the safety function is activated, the controller notifies you with a yellow symbol on the display. When the maximum temperature is no longer exceeded or when a protection function has switched off, a gray symbol will turn on to note the recent event. The list of alerts can be viewed in the "Information" menu.</p>
	<p>Error</p> <p>In the event of a sensor or communication connection failure, the controller informs you of the error with a red symbol on the display. If the error is corrected or is no longer present, a gray symbol indicates a recent event. The list of errors can be viewed in the "Information" menu.</p>

TEMPERATURES

The number of temperatures displayed on the screen depends on the selected hydraulic scheme and controller settings.



SYMBOLS FOR THE DISPLAY OF TEMP. AND OTHER DATA

Symbol	Description
	Calculated or requested temperature.
	Return-pipe temperature.
	Inlet temperature.
	Source temperature.
T1, T2, ...	Temperature sensors T1, T2.

HYDRAULIC SCHEME

The screen shows the selected hydraulic scheme with the display of measured temperatures.

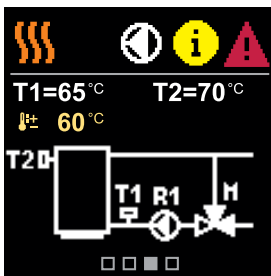

Hydraulic scheme with screen showing the measured temperatures

TIME AND DATE

The screen shows the day of the week, the current time and date.

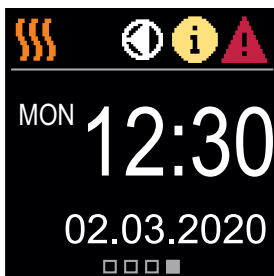





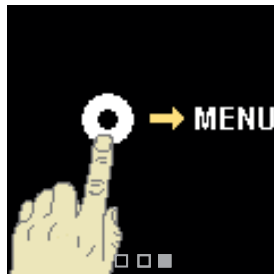
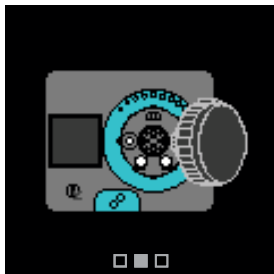

Time and date

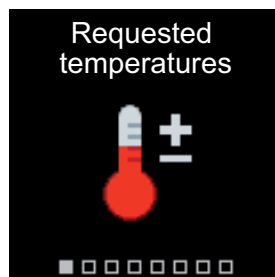
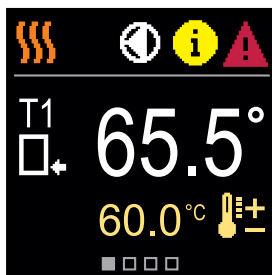
By pressing the  button we can start the display animation, which leads us to the additional settings menu.



ENTERING AND NAVIGATING THROUGH THE MENU



Press the  button to enter the menu.
Navigate through the menu with the  and  buttons and use the  button to confirm your selection. Press the button  to return to the previous screen.

MENU STRUCTURE AND DESCRIPTION

The menu consists of eight main groups:

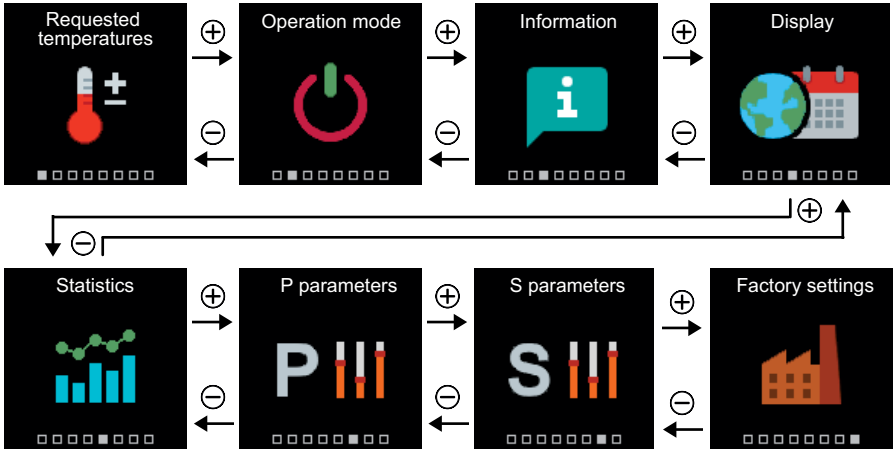

REQUESTED TEMPERATURES

In the menu, you can change the setting of the requested temperatures according to the selected hydraulic scheme.

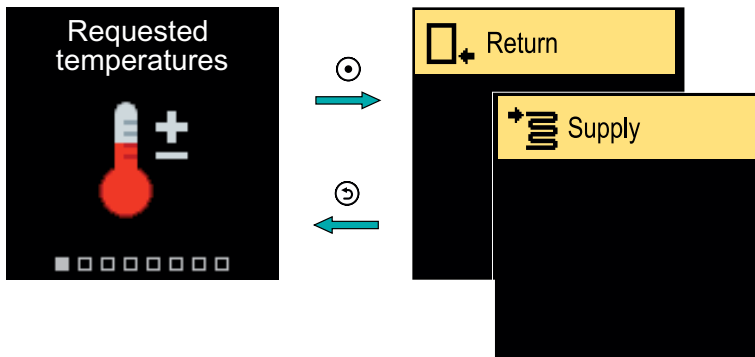

Navigate through the menu with the \ominus and \oplus buttons and use the \odot button to confirm your selection. A new screen with temperatures will open.

REQUESTED RETURN-PIPE TEMPERATURE

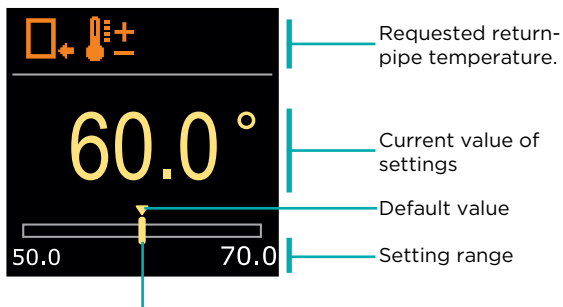

Current value of the requested temperature

Use the buttons \ominus and \oplus to select the requested temperature and confirm it with the \odot button. Exit the setting by pressing $\omin�$.

REQUESTED STAND-PIPE TEMPERATURE

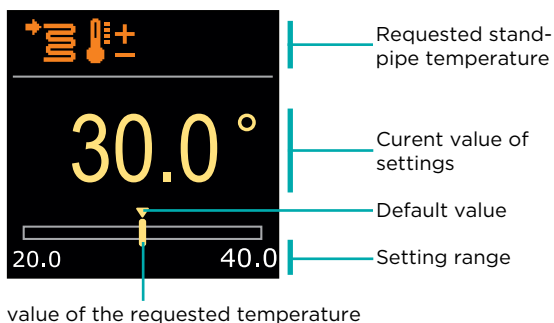

Current value of the requested temperature

Use the buttons ⊖ and ⊕ to select the requested temperature and confirm it with the ◉ button. Exit the setting by pressing ⊙.



We can only set a temperature value that is available for the selected scheme.

OPERATION MODE

In the menu, you can select the requested operation mode and other operation options.

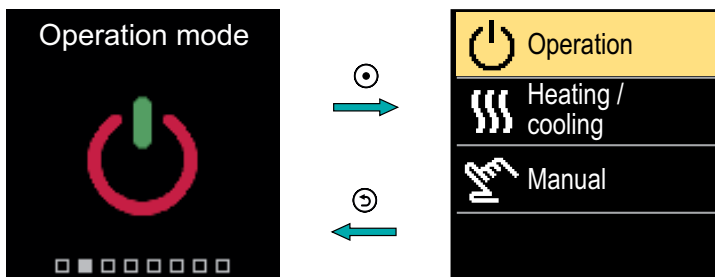

Navigate through the menu with the \ominus and \oplus buttons and use the \odot button to confirm your selection.

TURN OPERATION ON/OFF

In the menu, turn the operation on or off.

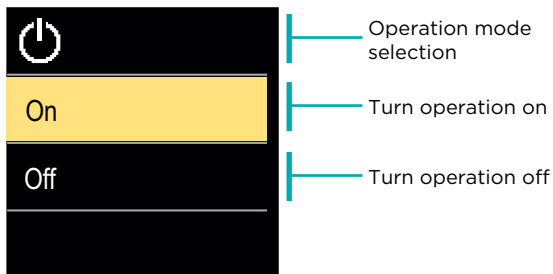

Use the \ominus and \oplus buttons to select the requested operation and confirm it by pressing \odot . Exit the setting by pressing \odot .

SELECTING HEATING OR COOLING OPERATION

In the menu, select the requested heating or cooling operation mode.

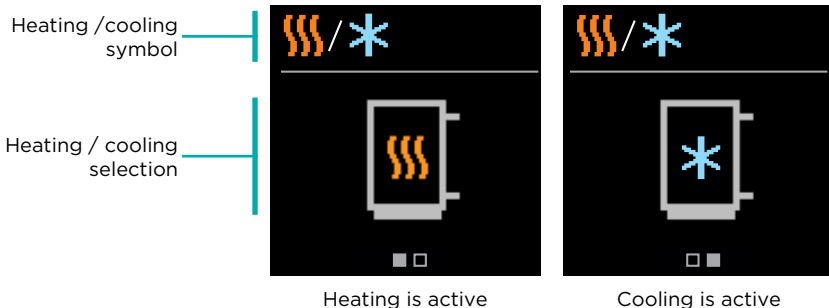

You can select heating or cooling with the \ominus and \oplus buttons and confirm it with the \odot button. Exit the setting by pressing \odot .

MANUAL OPERATION MODE

This operation mode is used when testing the heating system or in the event of a malfunction. The control output can be manually switched on, switched off or automatic operation can be selected.

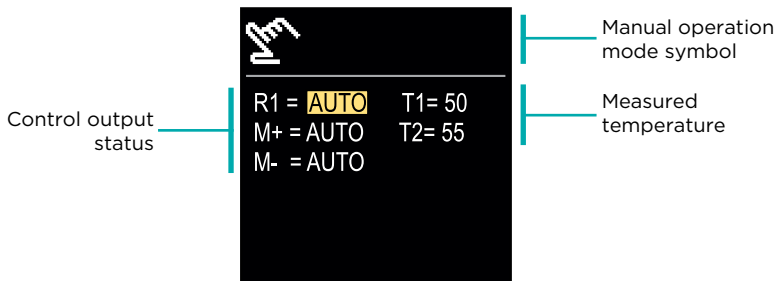

With the buttons \ominus and \oplus you can move between the individual outputs R1, M- or M+, and with the button \odot you can select the AUTO, OFF or ON status. Exit the setting by pressing \odot .

The menu is used to display information about the controller, notifications and errors.

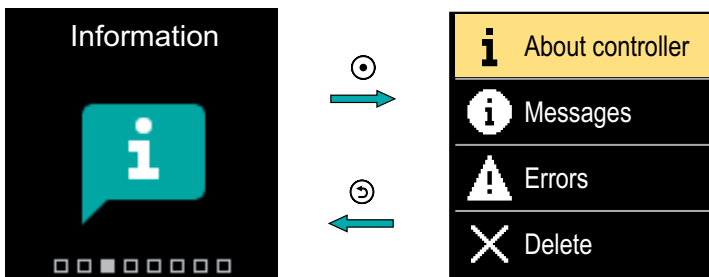

Navigate through the menu with the \ominus and \oplus buttons and use the \odot button to confirm your selection.

ABOUT THE CONTROLLER

The basic information about the controller is displayed on the screen.



Exit the screen with the \odot button.

MESSAGES

A list of messages is displayed on the screen with the time and date of the individual message.

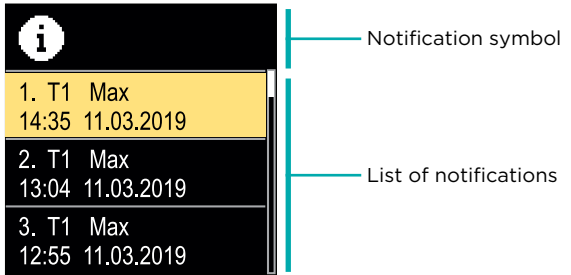

Navigate through the notifications with the \ominus and \oplus buttons.
Exit the screen with the button \odot .

ERRORS

A list of errors is displayed on the screen with the time and date of the individual errors.

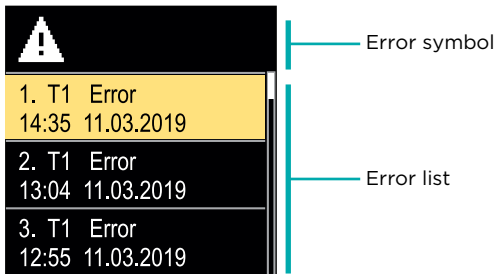

Navigate through the error list with the \ominus and \oplus buttons.
Exit the screen with the button \odot .

DELETING THE MESSAGES AND ERRORS

The list of messages and errors is deleted. The list of warnings for errors of all unconnected sensors is also deleted.



Sensor errors that are essential for the controller operation cannot be deleted.

The deletion must be confirmed by entering the 4-digit unlock code.

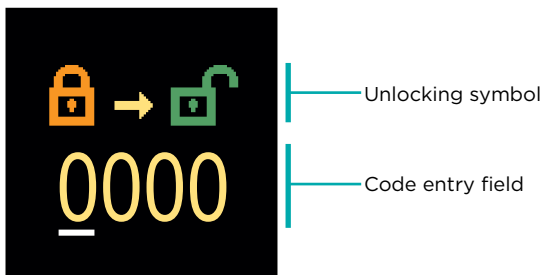

With the buttons \ominus and \oplus you can change the underlined number and with the button \odot you can move on to the next position. When the correct code is entered, the controller executes the delete command. Cancel the deletion with the \odot button.



The factory set code is "0001".

The menu is for basic on-screen display settings.

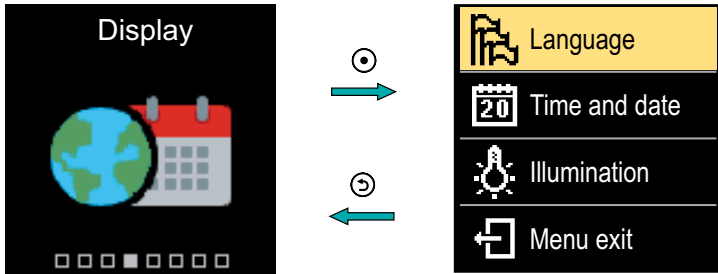

Navigate through the menu with the \ominus and \oplus buttons and use the \odot button to confirm your selection.

LANGUAGE SELECTION

A list of available languages appears on the screen.

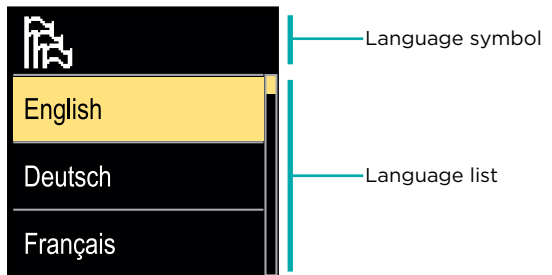

Use the \ominus and \oplus buttons to select the language and confirm it with the \odot button. Exit the setting with the \odot button.

TIME AND DATE SETTINGS

You can set the exact time and date.

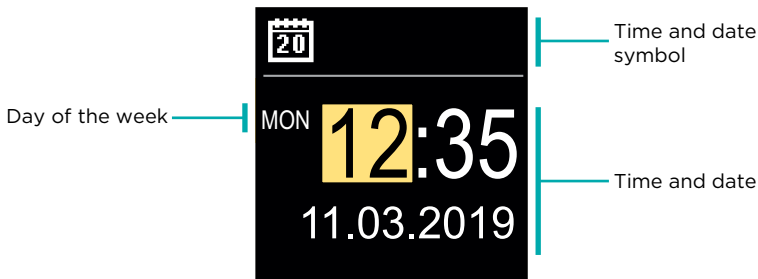

With the buttons \ominus and \oplus you can change the value and with the button \odot you can move on to the next data. Exit display with the button \odot .

ADJUSTING THE SCREEN BRIGHTNESS

You can adjust the screen brightness.

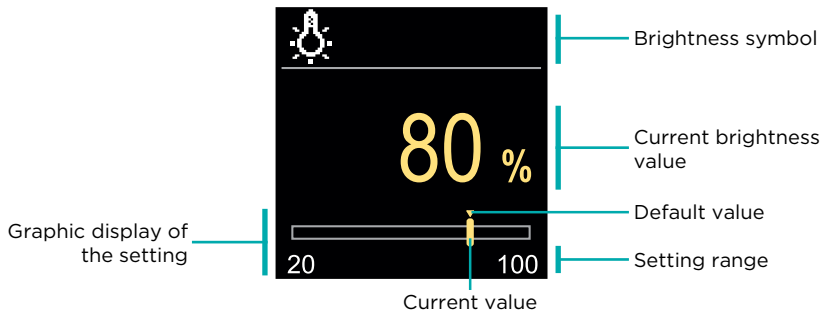

Use the \ominus and \oplus buttons to adjust the brightness and confirm it with the \odot button. Exit the setting with the \odot button.

SETTING THE MENU EXIT TIME

You can set the time to automatically exit the menu

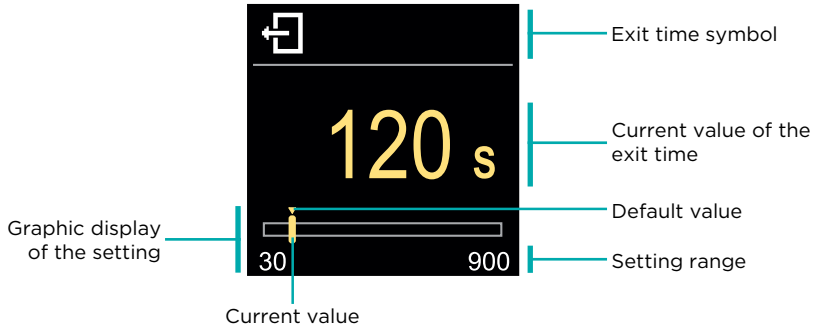

With the \ominus and \oplus buttons you can set the automatic exit time and confirm it with the \odot button. Exit the setting with the \odot button.

The menu is intended to display detailed information on the operation of the controller.

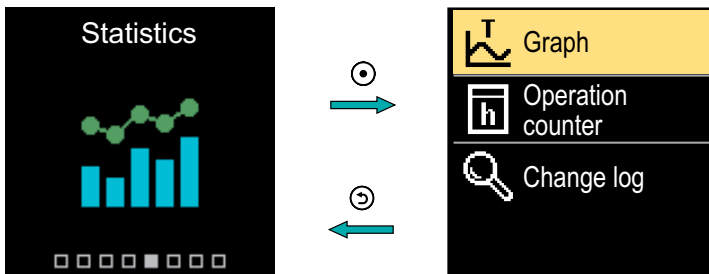

Navigate through the menu with the \ominus and \oplus buttons and use the \odot button to confirm your selection.

TEMPERATURE GRAPH

A 24-hour temperature graph for all two temperature sensors is displayed on the screen.

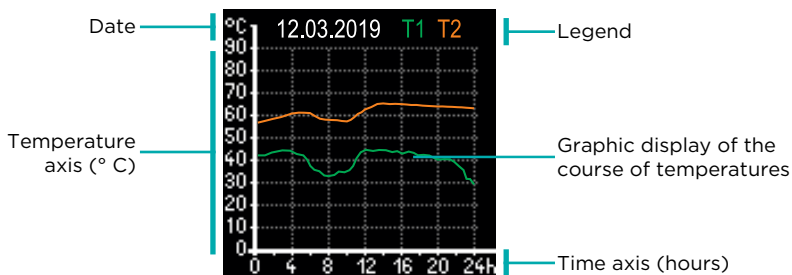



With the buttons \ominus and \oplus you can browse the temperature graphs for the last 7 days of operation. Exit the setting by pressing \odot .

OPERATION COUNTER

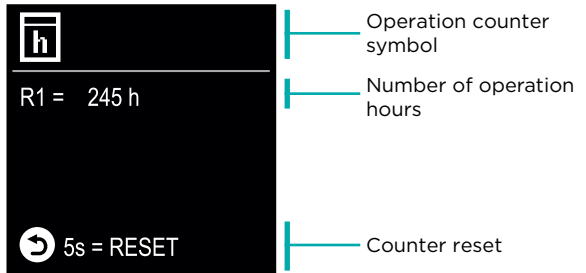
The display shows the number of operation hours of the R1 circulation pump output.



By pressing the button  for 5 seconds, you can reset the counter to 0. Exit the setting by pressing .

CHANGE LOG

A list of changed P and S parameters of the controller is displayed on the screen.

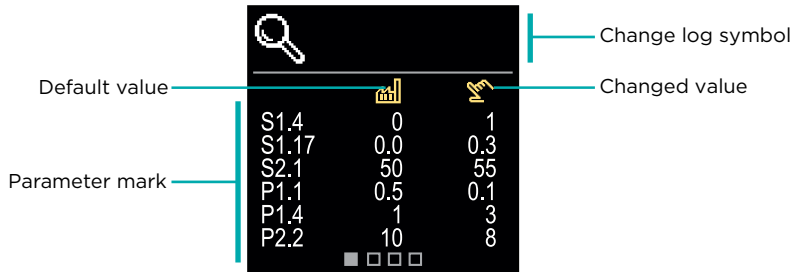

Navigate through the change list with the buttons  and . Exit the screen with the button .

USER P PARAMETERS

The menu is used to display and set user parameters.
The parameters are classified into group **P1** - general settings.

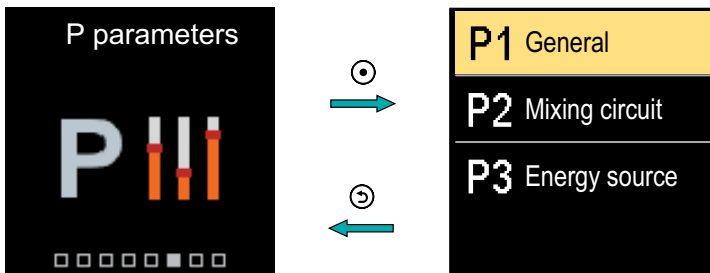

Navigate through the menu with the ⊖ and ⊕ buttons. When you use the ⊕ button to select the requested parameter group, a display will open describing the first parameter in the group.

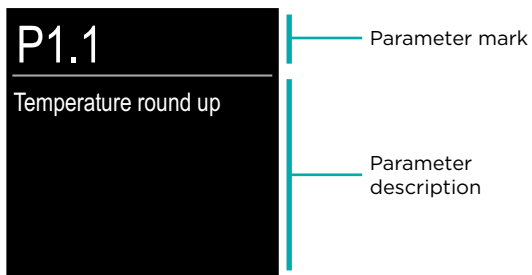

With the ⊖ and ⊕ buttons navigate through the parameters in the selected group. The parameter you want to change is selected by pressing the ⊕ button. The parameter setting screen, which can take the form of a menu or a slider, opens.

Menu format setting:

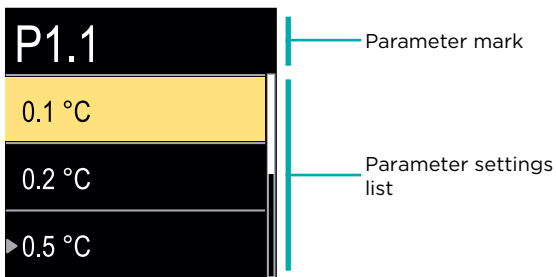

Use the \ominus and \oplus buttons to select the requested setting and confirm it with the \odot button. Exit the setting with the \odot button.

Slider format setting:

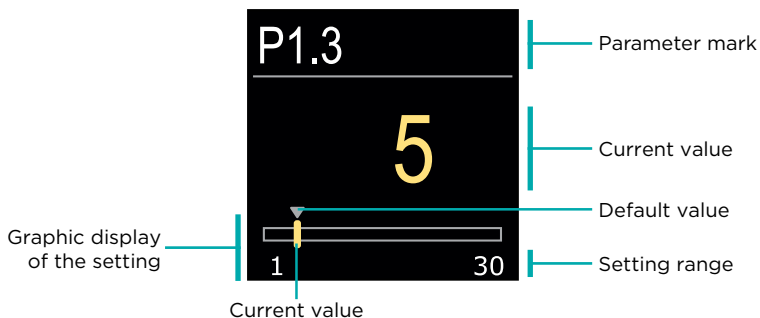

Use the buttons \ominus and \oplus to set the requested value and confirm it with the \odot button. Exit the setting with the \odot button.

P1 - BASIC SETTINGS

Parameter	Parameter name	Parameter description	Setting range	Default value
P1.1	Temperature round up	You set the accuracy of displayed temperatures.	- 0.1 °C - 0.2 °C - 0.5 °C - 1.0 °C	0.5 °C
P1.2	Automatic shift of clock to summer/winter time	With the help of a calendar, the controller carries out the automatic changeover between summer and winter time.	- No - Yes,	Yes
P1.4	Tones	By setting this field you define sound signals of the controller.	- Off - Keypad - Errors - Keypad and errors	Keypad
P1.6	Sensitivity of "Help" key	This setting sets the sensitivity of the "Help" key.	0 ÷ 100%	40%

The menu is used to display and set user parameters. The parameters are classified into groups **S1** - general settings, **S2** - settings for the heating circuit and **S3** - settings for the power source.

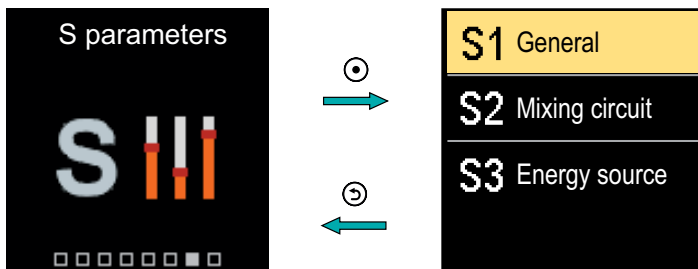

Navigate through the menu with the \ominus and \oplus buttons. When you use the \oplus button to select the requested parameter group, a display will open describing the first parameter in the group.

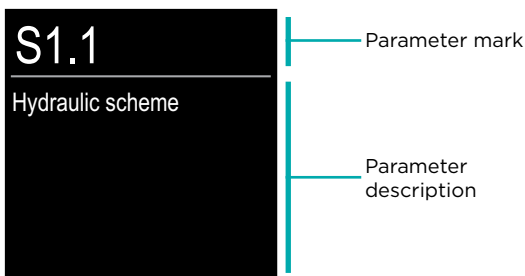

With the \ominus and \oplus buttons navigate through the parameters in the selected group. The parameter you want to change is selected by pressing the \oplus button. The parameter setting screen opens.



Only a trained professional shall perform the changing of service parameters.

SERVICE S PARAMETERS

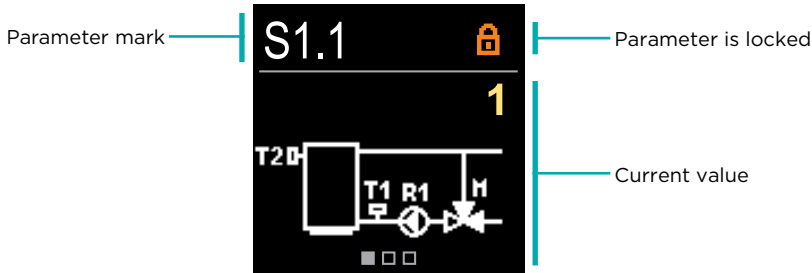

With the \ominus and \oplus buttons navigate through the parameters in the selected group. The parameter you want to change is selected by pressing the \odot button.

The S parameters are locked at the factory, so they must be unlocked by entering the 4-digit unlock code before changing.

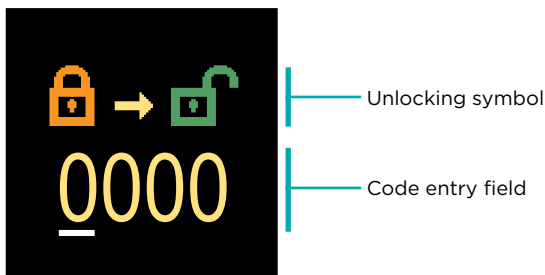

With the buttons \ominus and \oplus you can change the value and with the button \odot you move on to the next position and confirm the unlocking.



The factory set code is "0001".

When the parameter is unlocked, you can use the buttons \ominus and \oplus to set the requested value and press \odot to confirm. Exit the setting by pressing \odot .

S1 - BASIC SETTINGS

Parameter	Parameter name	Parameter description	Setting range	Default value
S1.1	Hydraulic scheme	Selection of hydraulic scheme.	1 ÷ 3	1
S1.2	Code for unlocking the service settings	This setting enables the change of code which is necessary to unlock the service settings. WARNING! Keep new code on a safe place. Without this code is impossible to change service settings	0000 ÷ 9999	0001
S1.3	Actuator turning direction	Setting of actuator turning direction - valve opening.	- Left - Right	Left
S1.4	Antiblock function for mixing valve and pump	If no control output has been switched on in a specific time frame (in a week or day), it automatically turns on for 60 seconds.	- No - Yes, weekly - Yes, daily	No
S1.6	Setting heating / cooling mode	This setting can prevent the possibility of switching between heating and cooling by limiting operation to heating or cooling only.	- heating and cooling - only heating - only cooling	Heating and cooling
S1.7	Selection of COM/ AUX input function	The setting determines the operation mode of the COM input. - COM: Communication input. - AUX (On): Activates controller operation when a short circuit is detected at the input. - AUX (Cooling): Switches the controller operation mode to cooling when a short circuit is detected at the input.	- COM - AUX (Operation on) - AUX (Cooling)	COM
S1.17	Sensor T1 calibration	Correction of measured temperature for sensor T1.	-5 ÷ 5 °C	0 °C
S1.18	Sensor T2 calibration	Correction of measured temperature for sensor T2.	-5 ÷ 5 °C	0 °C

S2 - MIXING CIRCUIT SETTINGS

Parameter	Parameter name	Parameter description	Setting range	Default value
S2.1	Minimum supply temperature T1 in heating mode	If protection of the heat source is enabled (parameter S3.1=2 or S3.1=3), this setting defines the setpoint temp. T1 by scheme 1, if the protection is active. This parameter also determines the lower limit of setpoint temperature T1. The setpoint temperature cannot be set lower than specified by this parameter.	15 ÷ 70 °C	Scheme 1: 50°C Scheme 2: 20°C Scheme 3: 20°C
S2.2	Maximum supply temperature T1 in heating mode	If protection of the heat source is enabled (parameter S3.1=2 or S3.1=3), this setting defines the setpoint temp. T1 by schemes 2 & 3, if the protection is active. This parameter also determines the upper limit of setpoint temperature T1. The setpoint temperature cannot be set higher than specified by this parameter.	15 ÷ 90 °C	Scheme 1: 70°C Scheme 2: 40°C Scheme 3: 40°C
S2.3	Minimum supply temperature T1 in cooling mode	If protection of the cooling source is enabled (parameter S3.5=1 or S3.5=3), this setting defines the setpoint temp. T1 by schemes 2 & 3, if the protection is active. This parameter also determines the lower limit of setpoint temperature T1. The setpoint temperature cannot be set lower than specified by this parameter.	5 ÷ 30 °C	16 °C
S2.4	Maximum supply temperature T1 in cooling mode	If protection of the cooling source is enabled (parameter S3.5=1 or S3.5=3), this setting defines the setpoint temperature T1 by scheme 1, if the protection is active. This parameter also determines the upper limit of setpoint temperature T1. The setpoint temperature cannot be set higher than specified by this parameter.	10 ÷ 40 °C	40 °C
S2.7	Backlash of mixing valve (seconds)	Setting of mixing valve running time to compensate the backlash of actuator and mixing valve assembly, which occurs by change of rotation direction.	0 ÷ 5 seconds	1 s

SERVICE S PARAMETERS

Parameter	Parameter name	Parameter description	Setting range	Default value
S2.8	Mixing valve P - constant	Setting of mixing valve position correction intensity. Smaller value means shorter movements, higher value means longer movements.	0.5 ÷ 2.0	1
S2.9	Mixing valve I - constant	Setting of mixing valve control frequency - how often mixing valve position is being controlled. Smaller value means low frequency, higher value means higher frequency	0.4 ÷ 2.5	1
S2.10	Mixing valve D - constant	Sensitivity of mixing valve for stand-pipe temperature changes. Smaller value means low sensitivity, higher value means high sensitivity.	0.4 ÷ 2.5	1
S2.13	Boiler circulation pump - boiler temperature increase time (seconds)	This function is used to control the return to the solid fuel boiler. Within the set time, the controller detects a 2 °C increase in the boiler temperature. If a boiler increase is detected, the controller starts the circulation pump.	30 ÷ 900 seconds	300 s
S2.14	Boiler circulation pump - operating mode	This setting determines the operation of the boiler circulation pump: - Standard - means that the pump operates according to the set minimum system temperature and when the differential between the boiler and the return-pipe is exceeded. - Constant - means that the pump operates whenever the boiler temperature gets higher than the set minimum system temperature. This mode can be used for pellet boilers when there is no sensor in the heat storage.	- Standard - Constant	Standard

SERVICE S PARAMETERS

Parameter	Parameter name	Parameter description	Setting range	Default value
S2.15	Circulation pump - switch-off delay (seconds)	Setting of delayed circulation pump switch-off when there is no requirement for heating.	30 ÷ 900 seconds	300 s
S2.16	Boiler circulation pump - switch off differential T2-T1 (°C)	This setting determines the differential between the sensors T2 and T1, under which the circulation pump of the boiler is switched off.	2.0 ÷ 8.0 °C	3.0 °C
S2.19	Initial valve movement from open position (seconds)	Setting of initial valve movement duration when moving from open position. With this setting the valve is moved to its control range and immediate controller respond at startup of system.	0 ÷ 30 seconds	20 s
S2.20	Initial valve movement from closed position (seconds)	Setting of initial valve movement duration when moving from closed position. With this setting the valve is moved to its control range and immediate controller respond at startup of system.	0 ÷ 30 seconds	20 s

S3 - SERVICE SETTINGS FOR ENERGY SOURCE

<i>Parameter</i>	<i>Parameter name</i>	<i>Parameter description</i>	<i>Setting range</i>	<i>Default value</i>
S3.1	Protection of the heat source	<p>With the setting, we choose which limit temperatures are considered for the protection of the heat source.</p> <ul style="list-style-type: none"> - No protection. - Only protection of min. temperature (parameter S3.3). - Only protection of max. temperature (S3.4 parameter). - Protection of min. and max. temp. (parameters S3.3 and S3.4). <p>Protection of min. heat source temperature is active if min. temperature is not exceeded. Controller does not turn on the circulation pump and does not control the mixing valve. Protection mode for heat source max. temp. is set with parameter S3.2</p>	<ul style="list-style-type: none"> - No protection - Tmin - Tmax - Tmin and Tmax 	Tmin and Tmax

Parameter	Parameter name	Parameter description	Setting range	Default value
S3.2	Operation mode for exceeded max. heat source temperature	<p>This setting determines how the controller protects the heat source, if its temperature exceeds max. value.</p> <ul style="list-style-type: none"> - Priority protection of the heat source: <p>In the event that $T_2 > T_{2max}$, the controller unconditionally opens the mixing valve. When heat source temperature drops below $T_2 < T_{2max}$ - Parameter S3.5, the controller reactivates the regular mixing valve control.</p> <ul style="list-style-type: none"> - Limited heat source protection: <p>In the event that $T_2 > T_{2max}$, the controller:</p> <ul style="list-style-type: none"> - decreases setpoint temperature to T_{1min} (parameter S2.1), for scheme 1 - increases setpoint temperature to T_{1max} (parameter S2.2), for schemes 2, 3 - Priority protection of the heating system: <p>If $T_2 > T_{2max}$, the controller unconditionally closes the mixing valve. When $T_2 < T_{2max}$ - Parameter S3.5, the controller reactivates the regular mixing valve control.</p>	<ul style="list-style-type: none"> - Source protection - Limited source protection - System protection 	Limited source protection
S3.3	Minimum temperature of T2 sensor in the heating mode (°C)	Minimum temperature of sensor T2 in heating mode is set.	5 ÷ 70 °C	50 °C
S3.4	Minimum temperature of T2 sensor in the heating mode (°C)	Maximum temperature of sensor T2 in heating mode is set.	10 ÷ 100 °C	85 °C
S3.5	Hysteresis for heat source protection	Setting of hysteresis for deactivation of heat source protection.	1 ÷ 10 °C	5 °C

SERVICE S PARAMETERS

Parameter	Parameter name	Parameter description	Setting range	Default value
S3.9	Protection of the cooling source	<p>With the setting, we choose which limit temperatures are considered for the protection of the cooling source.</p> <ul style="list-style-type: none">- No protection.- Tmin: Only protection of min. temperature (parameter S3.11).- Tmax: Only protection of max. temperature (parameter S3.12).- Tmin and Tmax: Protection of min. and max. temperature (parameters S3.11 and S3.12). <p>Protection mode for cooling source min. temperature is set with parameter S3.10 Protection of max. cooling source temperature is active if max. temperature is exceeded. Controller does not turn on the circulation pump and does not control the mixing valve.</p>	<ul style="list-style-type: none">- No protection- Tmin- Tmax- Tmin and Tmax	<p>Tmin in Tmax</p>

Parameter	Parameter name	Parameter description	Setting range	Default value
S3.10	Operation mode for exceeded min. cooling source temperature	<p>This setting determines how the controller protects the cooling source, if its temperature drops below min. value.</p> <ul style="list-style-type: none"> - Priority protection of the cooling source: <p>In the event that $T_2 < T_{2min}$, the controller unconditionally opens the mixing valve. When $T_2 > T_{2min} + \text{Parameter S3.13}$, the controller reactivates the regular mixing valve control.</p> <ul style="list-style-type: none"> - Limited heat source protection: <p>In the event that $T_2 < T_{2min}$, the controller:</p> <ul style="list-style-type: none"> - increases setpoint temperature to T_{lmax} (parameter S2.4), for scheme 1 - decreases setpoint temperature to T_{lmin} (parameter S2.3), for schemes 2 and 3 <ul style="list-style-type: none"> - Priority protection of the heating system: <p>If $T_2 < T_{2min}$, the controller unconditionally closes the mixing valve. When $T_2 > T_{2min} + \text{Parameter S3.13}$, the controller reactivates the regular mixing valve control.</p>	<ul style="list-style-type: none"> - Source protection - Limited source protection - System protection 	Limited source protection
S3.11	Minimum temperature of T2 sensor in the cooling mode (°C)	Minimum temperature of sensor T2 in cooling mode is set.	$-20 \div 20 \text{ } ^\circ\text{C}$	5 °C
S3.12	Maximum temperature of T2 sensor in the cooling mode (°C)	Maximum temperature of sensor T2 in cooling mode is set.	$10 \div 50 \text{ } ^\circ\text{C}$	30 °C
S3.13	Hysteresis for cooling source protection	Setting of hysteresis for deactivation of cooling source protection.	$1 \div 10 \text{ } ^\circ\text{C}$	2 °C

The menu contains tools for resetting the controller to saved or factory settings.

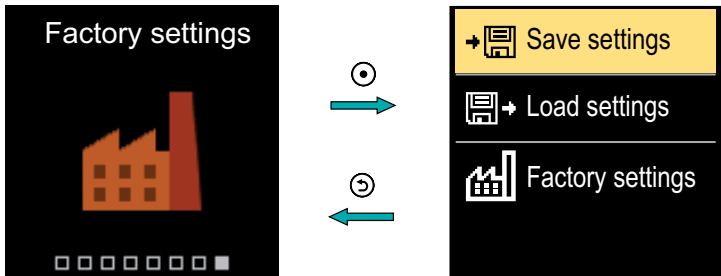

Navigate through the menu with the \ominus and \oplus buttons. When you use the button \odot to select the request command, a display will open for unlocking or confirming the command. Exit the setting with the \odot button.

Symbol	Description
	Save user settings as a backup.
	Load user settings from backup. If a backup doesn't exist, this command is not executed.
	Restores all parameters to default values and restarts the controller initial setup.

CLUTCH AND MANUAL VALVE DISPLACEMENT

Pressing the clutch I. activates the manual valve displacement. You can now move the mixing valve by turning the button II. To return to automatic operation, press the clutch I. again. When the clutch is activated, the clutch symbol appears on the display.

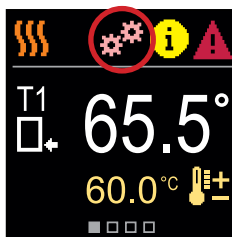
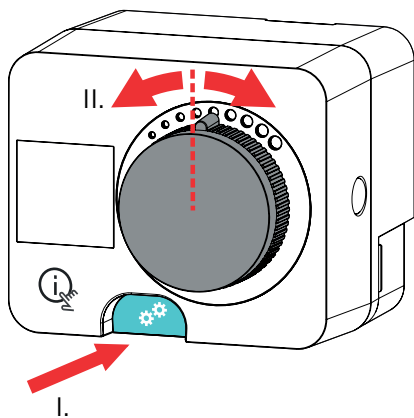



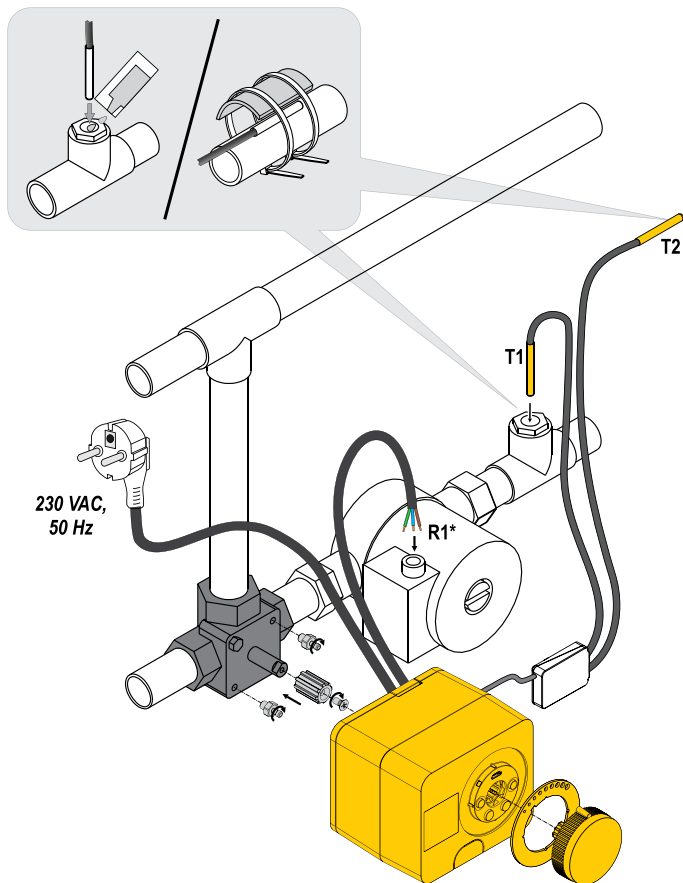

CONTROLLER INSTALLATION

EN

In a dry and warm interior, the controller can be mounted directly on the mixing valve with the help of the accessories provided. Avoid close proximity to any strong electromagnetic fields.

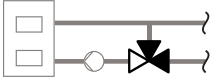
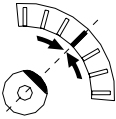
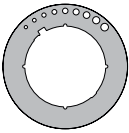
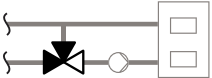
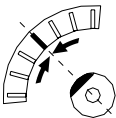
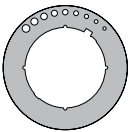

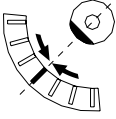
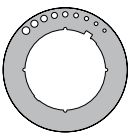
CONTROLLER INSTALLATION

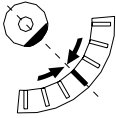
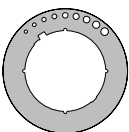
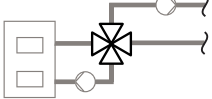
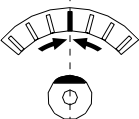
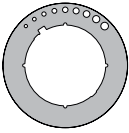
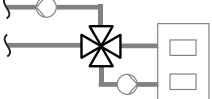
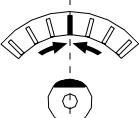
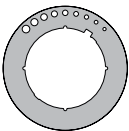
Scheme	Mixing valve position	Ring position
		
		
		
		
		
		

CONTROLLER POWER CONNECTION

EN

i

Any project with an ACD controller must be based on calculations and plans that are solely yours and in accordance with applicable regulations. Images and texts in these instructions serve as examples and the issuer does not assume any responsibility for them. The liability of the issuer for unprofessional, incorrect and false information that can result in damage is explicitly excluded. We reserve the right to technical errors or changes without giving prior notice.



The connection of controlling devices should be performed by an expert with an appropriate qualification, or by an authorised organisation. Before touching any wiring, make sure that the main switch is off. Low voltage installation regulations IEC 60364 and VDE 0100, statutory provisions for accident prevention, statutory provisions for environmental protection and other national rules must be observed.

CONNECTION OF TEMPERATURE SENSORS

Temperature sensors are connected to a pre-wired connecting rail. The controller allows the connection of two Pt1000 temperature sensors (connection terminals 1 to 4). The sensor function depends on the hydraulic diagram.

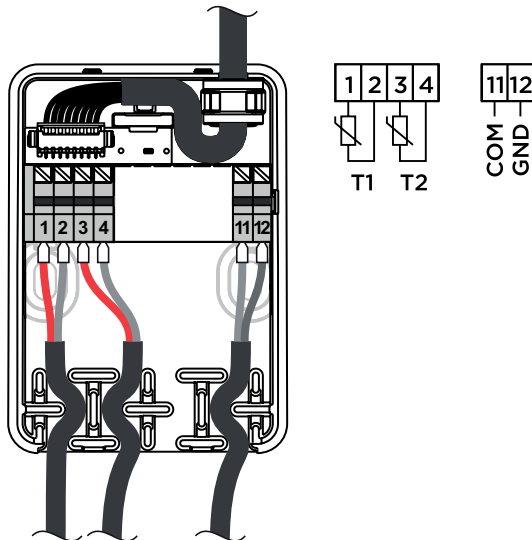

OPERATION MODES WITH SENSOR FAILURE

Sensor T1 is not connected or is faulty.

- Heating: The controller switches on the circulation pump. In scheme 1, the mixing valve opens and in schemes 2 and 3 it closes.
- Cooling: The controller switches off the circulation pump.

Sensor T2 is not connected or is faulty.

- Heating: The controller switches on the circulation pump. The mixing valve control works.
- Cooling: The controller switches off the circulation pump.

Resistance table for Pt-1000 temperature sensors

Temp. [°C]	Electrical resistance [Ω]	Temp. [°C]	Electrical resistance [Ω]	Temp. [°C]	Electrical resistance [Ω]	Temp. [°C]	Electrical resistance [Ω]
-20	922	35	1136	90	1347	145	1555
-15	941	40	1155	95	1366	150	1573
-10	961	45	1175	100	1385	155	1592
-5	980	50	1194	105	1404	160	1611
0	1000	55	1213	110	1423	165	1629
5	1020	60	1232	115	1442	170	1648
10	1039	65	1252	120	1461	175	1666
15	1058	70	1271	125	1480	180	1685
20	1078	75	1290	130	1498	185	1703
25	1097	80	1309	135	1515	190	1722
30	1117	85	1328	140	1536	195	1740

AUX FUNCTION AT COM INPUT

The COM input can also be used for external actuation of the controller.
The external actuation options are set with parameter S1.7.
When a short circuit is detected at COM input, the following is activated:

- switch from off to on of the heating if the parameter is set to S1.7 = Operation on.
- switch from heating to cooling if parameter is set to S1.7 = Cooling.

When the AUX function is activated, the AUX symbol appears on the display.

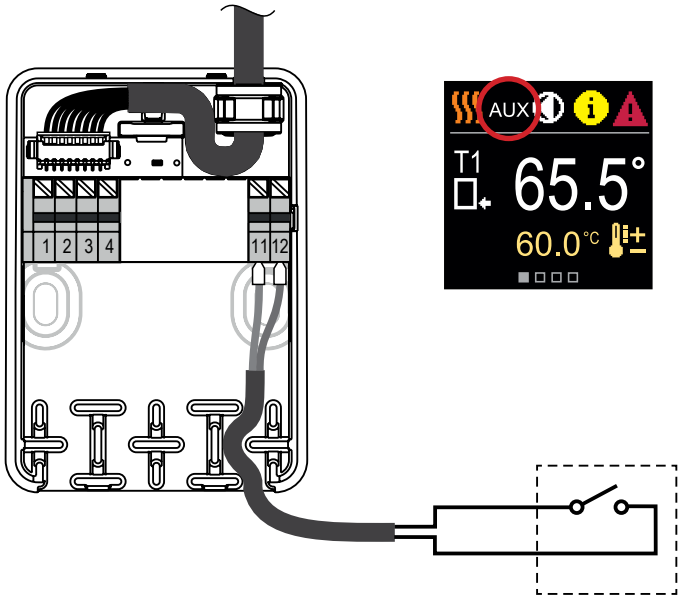

General technical data - regulator

Dimensions (W x H x D) 102 x 84 x 94 mm

Regulator weight - 800 g

Regulator casing PC - thermoplastic

Supply voltage 230 V - , 50 Hz

Own consumption 0.5 VA

Degree of protection IP42 according to EN 60529

Protective class I according to EN 60730-1

Permissible ambient temperature 5 °C to +40 °C

Permissible relative humidity max. 85% rH at 25 °C

Storage temperature -20 °C to +65 °C

Accuracy of built-in clock ± 5 min/year

Program class A

Storing data without power min. 10 years

Technical characteristics - sensors

Temperature sensor type Pt1000

Sensor resistance 1078 Ohm at 20 °C

Temperature range -25 ÷ 150 °C, IP32

Min. conductor cross-section for sensors 0.3 mm²

Max. length of sensor conductors max. 10 m

CAUTION! Installation diagrams show the principle of operation and do not contain all the auxiliary and safety elements! The applicable regulations must be observed during installation!

SCHEME 1 - RETURN-PIPE - HEATING

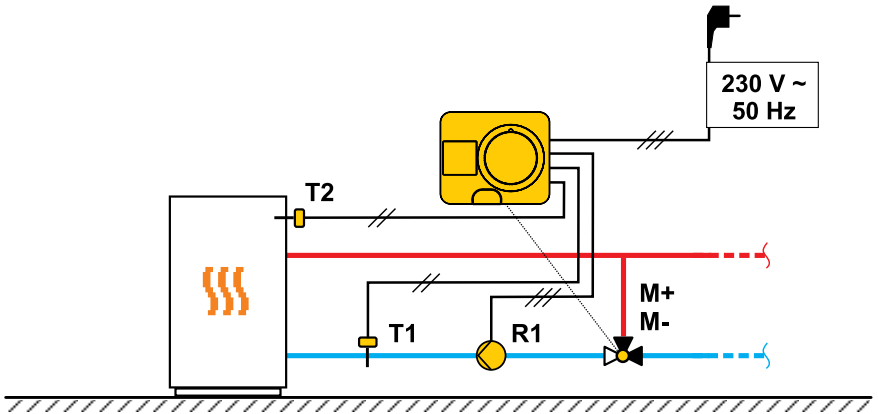

SCHEME 1 - RETURN-PIPE - COOLING

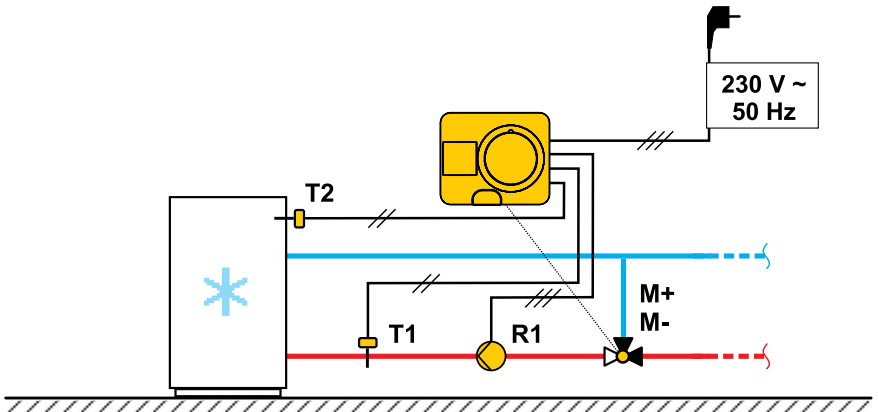

SCHEME 2 - SUPPLY - HEATING

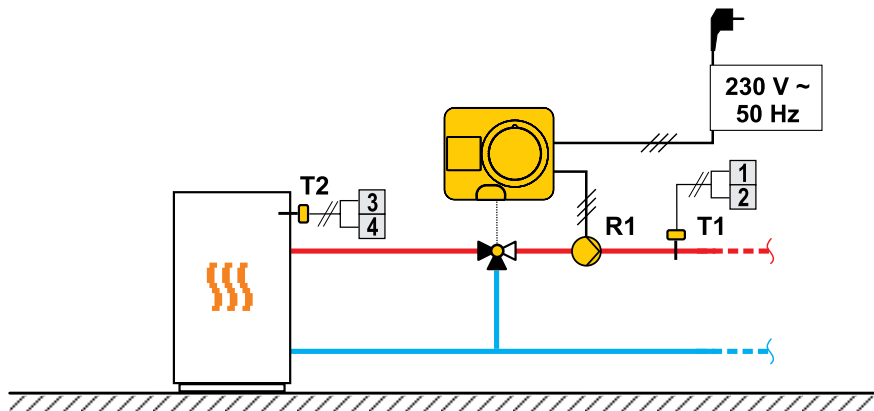

SCHEME 2 - SUPPLY - COOLING

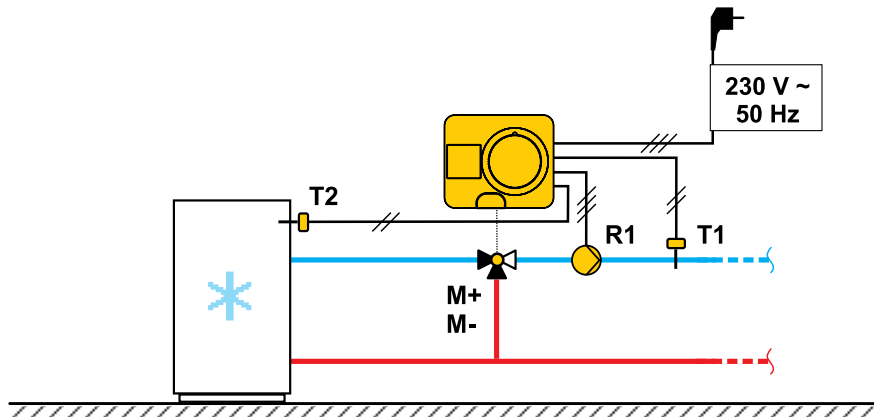

SCHEME 3 - SUPPLY CONTROL BY LIMITING THE RETURN-PIPE TEMPERATURE - HEATING

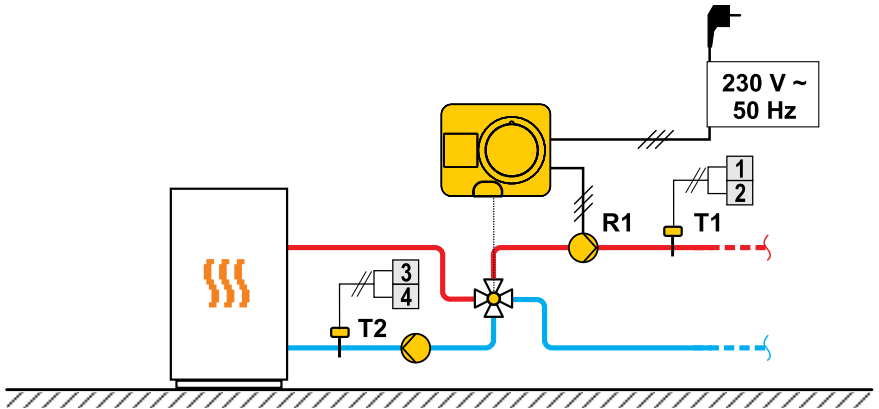

SCHEME 3 - SUPPLY CONTROL BY LIMITING THE RETURN-PIPE TEMPERATURE - COOLING

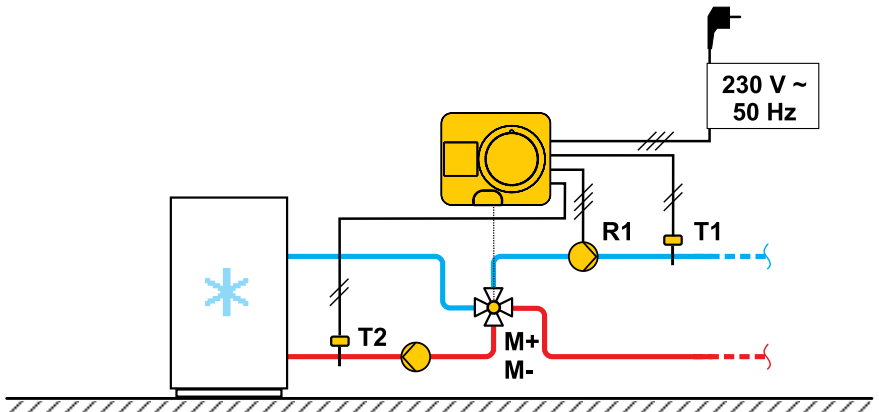

SELTRON

SMART HEATING

Seltron d.o.o.
Tržaška cesta 85 A
SL-2000 Maribor
Slovenia

T: +386 (0) 2 671 96 00
F: +386 (0) 2 671 96 66
info@seltron.si
www.seltron.eu

File export date: 21. 07. 2023



01MC060729